



# SUPER LOOP ANTENNA

# LA800

## Instruction manual



AOR Ltd.  
Authority On Radio Communications



## Table of contents

1. Introduction .....	1
2. Included in this package .....	2
3. Hardware setup .....	3
4. Operating instructions .....	6
5. Directivity of a loop antenna .....	7
6. Characteristics of a “shielded” loop antenna .....	8
7. Options .....	9
8. Specifications .....	10

# 1. Introduction

---

Thank you for purchasing the LA800 SUPER LOOP ANTENNA.

LA800 is AOR's new and first OUTDOOR and WATERPROOF shielded loop antenna for reception between 10kHz and 500MHz!

To get the best possible results from your LA800, we recommend that you read this manual and familiarize yourself with the antenna.

First, a word of caution: LA800 is a **RECEIVE ONLY** antenna. Do not transmit with it or its circuitry will be severely damaged, maybe even beyond repair.

In recent years, the increase in man-made local noise (typical city noise) poses a problem for the reception of distant signals in the long wave, medium wave and shortwave bands. LA800 is our latest product based on the technology we developed since the original LA320 indoor loop antenna. In addition to its exceptional directivity in order to minimize the effects of local noise, the revolutionary LA800 offers, with its **REMOTE TUNING SYSTEM**, the perfect solution to keep the antenna away from noise sources by setting it up in quiet areas! While the control (tuning) box stays at hand's reach, the WATERPROOF loop element can be permanently setup outdoors.

10kHz to 500MHz, 6 position band switch to peak only on the wanted signal. Built-in low noise amplifier for exceptional 20dB gain. Loop element diameter of 80cm for maximum reception performance.

**Remote tuning** – The supplied 10m control and coaxial cables, separating the antenna from the control box, allow to conveniently operate band switching and fine tuning controls placed on the control box..

**A relay system** is used for band switching, providing excellent isolation characteristics. The relay is efficiently placed inside the loop element, while you can operate it through the control box via the control cable.

**Electronic tuning** from 150kHz~30MHz allows very sharp tuning to the desired frequency. Shift the aligning point slightly to attenuate unwanted signals while amplifying the wanted signal.

**Waterproof** – The loop element's electronic circuitry is housed in a ABS plastic box, water and dust proof to IP65 standard.

## 2. Included in this package

No.	Description	Qty
①	Loop element	1
②	Two U-bolts for mast mount	1
③	Control box	1
④	Control cable (LAN type) 10m	1
⑤	BNC (F)/BNC (F) RG-58U coaxial cable 10m	1
⑥	AC power supply	1
⑦	Printed instruction manual	1
⑧	(for Japanese market only)	1
⑨	Product sticker for the loop element box	1



### 3. Hardware setup

---

#### **Caution!**

LA800 is a **RECEIVE ONLY** antenna. Do not transmit with it or its circuitry will be severely damaged, maybe even beyond repair.

As pictured below, mount the LA800 loop element to a (non-supplied) antenna mast, using the supplied U-bolts.

Antenna masts are typically sold at home centers.

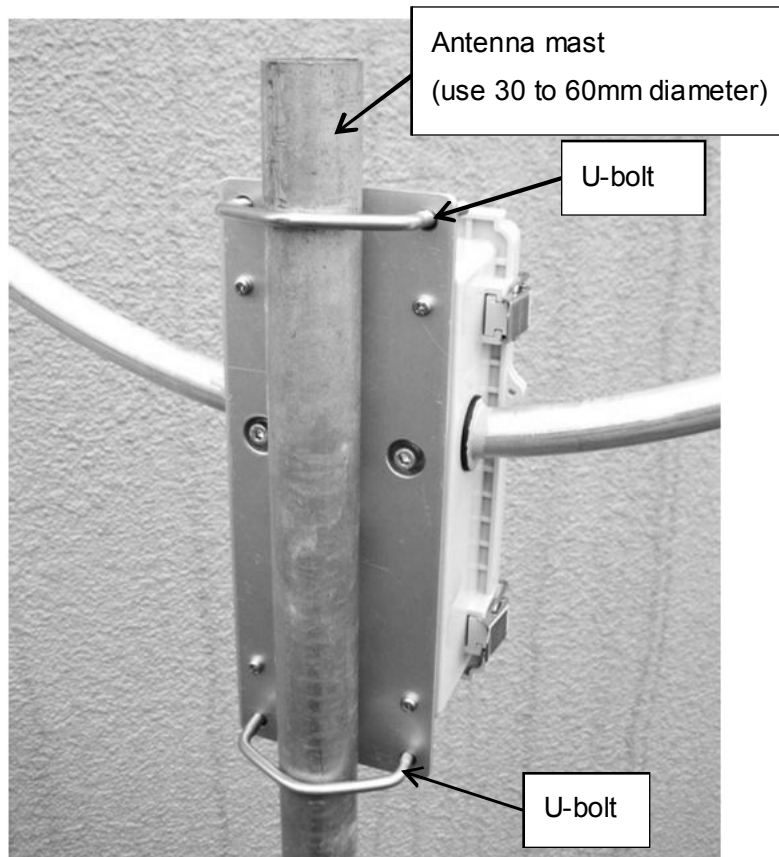

#### **SAFETY PRECAUTIONS**

- If you are installing an antenna for the first time, for your own safety as well as others, seek professional assistance.
- Installation of this antenna near power lines is dangerous. Do not work on the system or connect or disconnect cables during periods of lightning activity.
- Do not work on a wet or windy day.
- Do not locate the antenna near overhead power lines or other electric light or power circuits, or where it can come into contact with such circuits. When installing the antenna, take extreme care not to come into contact with such circuits, as they may cause serious injury or death.

For balcony mount, you can also use typical satellite dish balcony mounts, as pictured below. Such mounts are not supplied by AOR but are usually sold at home-centers.



The loop element's electronic circuitry is housed in an ABS plastic box, water and dust proof to IP65 standard.

- © The control and coaxial cables enter the plastic box through two rubber gaskets as shown below. Connect these to their respective sockets "ANT OUT" and "REMOTE".

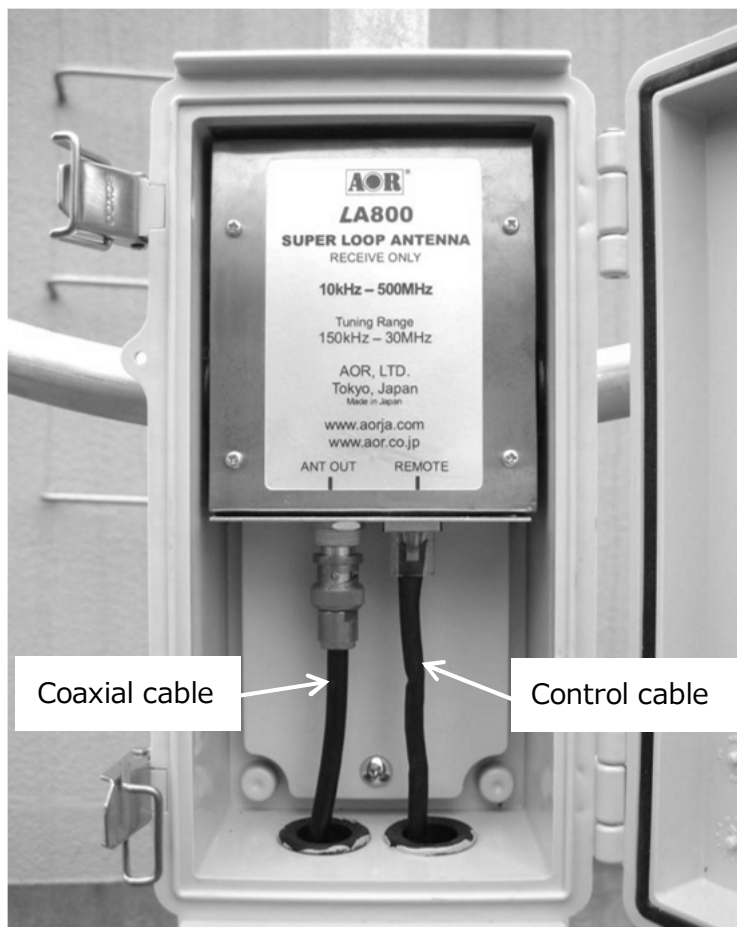

- © Run the coaxial and control cable a bit below and then back up to the hole into the building, thus providing a "drip loop" to prevent rain from running down the cable and into the building

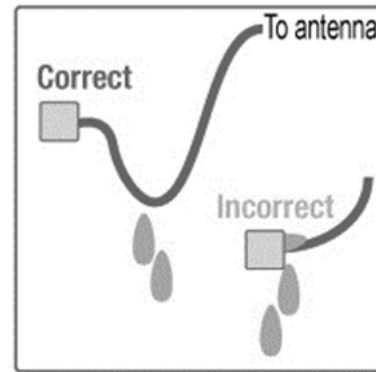

- © On the receiver side, connect the control cable to the control box and the coaxial cable directly to your receiver's antenna socket. Finally, connect the AC power supply to the control box.

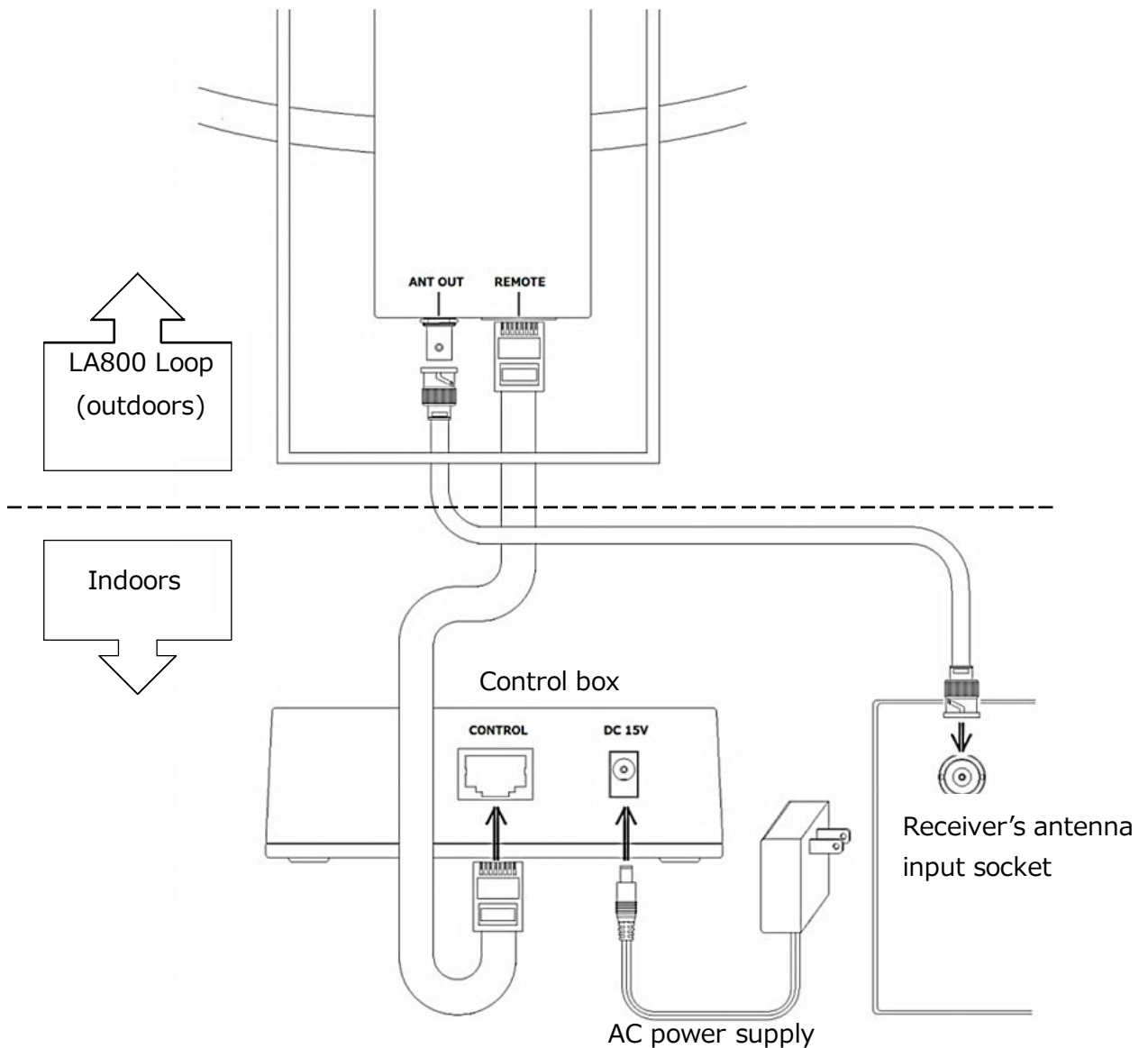

To connect LA800 to an antique receiver with 600Ω antenna terminal, use the optional MC-600 Impedance Matching Transformer.



## 4. Operating instructions

---

- ⦿ Connect the AC power supply and push the red power button on the control box. A blue LED will light up.
- ⦿ Tune your receiver to the desired frequency.
- ⦿ Now you need to select one of the 6 available band ranges, using the band switch numbered from 1 to 6. Refer to the printed switch number / band range information on the top of the control box.

Please note that position 6 is non-tunable, as the loop is wired to act as an amplified whip antenna.

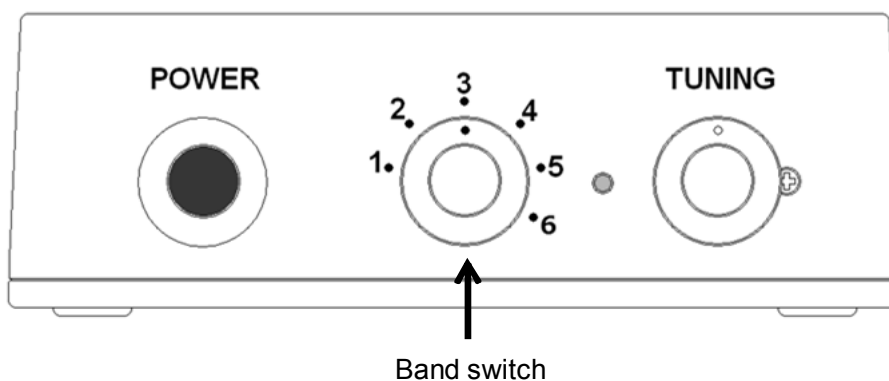

- ⦿ Peak the received signal by turning the TUNING knob slowly to either the left or the right. The white dot on the tuning knob helps you to see the approximate location of the tuning. For your reference, when the dot is on top as on the above illustration, the tuning PEAK is approximately in the middle of the selected band. For example for band switch position 1 (150kHz to 800kHz), it would be roughly peaked on 475kHz. Tuning is most critical above 3MHz. For best performance of LA800 and optimal reception conditions, make sure the selected band is appropriate for the received frequency, and search for the signal peak with the tuning knob.
- ⦿ A loop antenna is very directional. Reception can be improved by using a third party antenna mast rotator, and rotate the loop element until your receiver's signal strength meter (S-meter) deflects to maximum and the incoming signal sounds clearest. If your receiver does not have an S-meter, simply adjust for maximum received signal.

## 5. Directivity of a loop antenna

---

A significant advantage of a loop antenna is its directional pattern, a “figure 8” shape with two null points separated by 180 degrees. The null in reception that is located at right angles to the plane of the loop can be used for interference reduction. On the other hand, received signal strength is greatest in the directions indicated by the arrows.

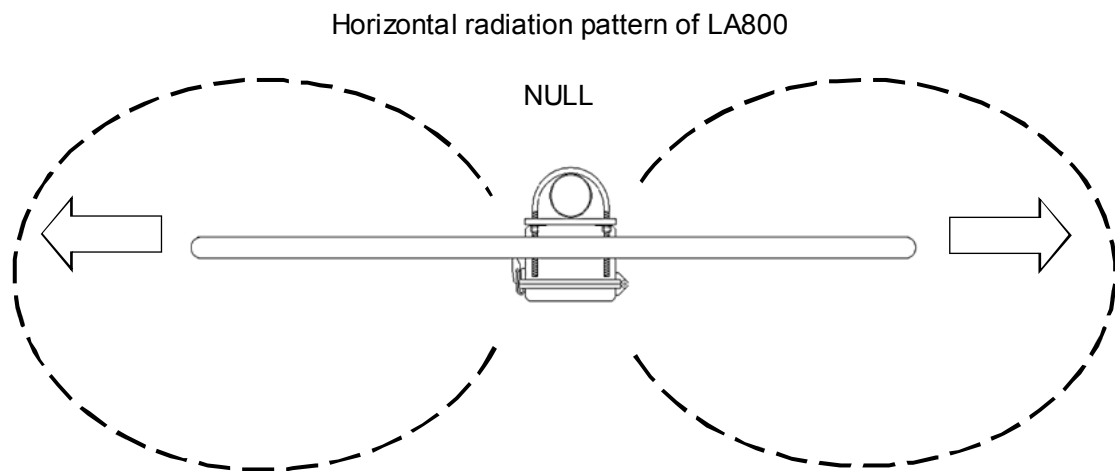

NULL: Angle from which magnitude of the radiation pattern decreases to zero. In other words, these are the sides from which the antenna receives the least.

 Maximum reception performance is achieved when these sides of the loop face the signal.

## 6. Characteristics of a “shielded” loop antenna

---

A shielded loop antenna is less susceptible to nearby electrical interference sources, thanks to the electrostatic shielding of the loop afforded by the grounded metallic conduit enclosing the wire coils.

By these principles, LA800 responds to the magnetic field rather than the electric field, thus efficiently isolating the low frequency electrostatic noise from the distant signal to be received.

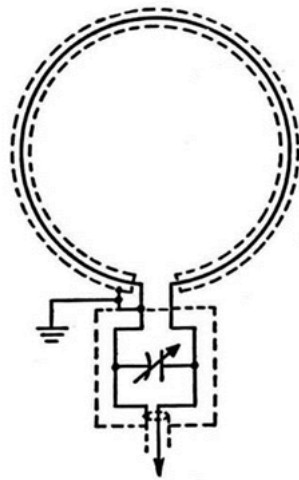

Shield circuit of LA800

With this design, all parts of the loop will have the same capacitance to ground. The shield also protects the loop from the *induction field* created by nearby disturbances. The induction field refers to the electric and magnetic fields in the immediate vicinity of an antenna. Those fields decrease rapidly in strength with distance, and the induction field is usually ignored. However, wires and other metal objects near the loop can take energy from a passing wave and produce induction fields that can induce spurious voltages in the loop.

A shield over a loop antenna will not appreciably decrease the amount of magnetic flux that passes through the loop when a wave goes by - as long as it does not form a complete turn. A gap is left in the shield so that it does not become a shorted turn. Without the gap, the shield would reduce the magnetic field linking the loop so that no signal could be received by the internal wire. With the gap, alternating currents can be induced in the metal shield and voltages will be induced in the internal wire.

## 7. Options

---

### GT-1 Galvanic isolation transformer

To be connected between the receiver and the LA800 antenna. Does greatly reduce local noise by breaking the ground loop effect between antenna and receiver.

Supported frequency range: 40kHz to 30MHz



### MC-600 Impedance matching transformer

Passive impedance matching transformer interface which allows your LA800 to be connected to any antique receiver with a 600Ω antenna terminal. Supported frequency range: 10kHz to 30MHz. MC-600 has the same isolation feature than the GT-1 accessory .



## 8. Specifications

LA800 Super Loop Antenna		
Loop size	Diameter: 780mm (to the pipe center)	
Loop type	Aluminum pipe: 20mm (2mm thick)	
Frequency range	10kHz ~ 500MHz	
Aligned range	150kHz ~ 30MHz (5 band selectable)	
Unaligned range	10kHz ~ 150kHz, 30MHz ~ 500MHz	
Gain	20dB min.	
Operating temperature	-10°C ~ +60°C	
Power requirements	12 ~ 16V DC	
Power consumption	Approx. 14mA~100mA (band dependent) (figures with supplied AC adapter)	
Impedance	50 Ohm	
Sizes (mm), projections included	Loop element	800(W)x970(H)x84(D)
	Control box	120(W)x38(H)x101(D)
Weight	Loop element	Approx. 1.4kg (Excluding mount U-bolts)
	Control box	Approx. 240g
Supported mount mast	30~60mm	
Supplied accessories	AC power supply Control cable (LAN type) 10m BNC (F)/BNC (F) RG-58U coaxial cable 10m Two U-bolts for mast mount Printed user manual	

- Product specifications and design subject to change without prior notice.

### Assembled dimensions:

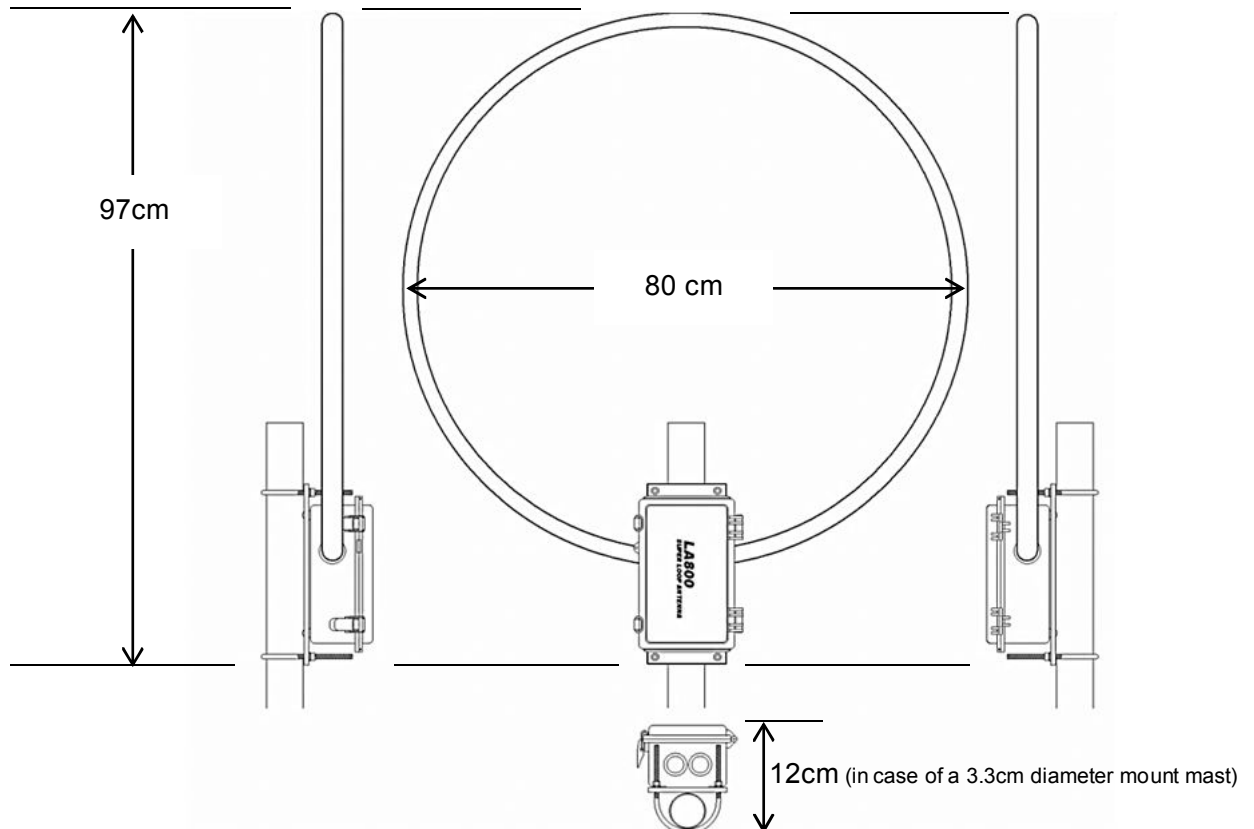

Memo:





Authority On Radio Communications

AOR Ltd.  
2-6-4 Misuji, Taito-ku, 111-0055 Tokyo, Japan  
[www.aorja.com](http://www.aorja.com)